

# BEL GRAPNEL 'J' CHAIN CHASERS

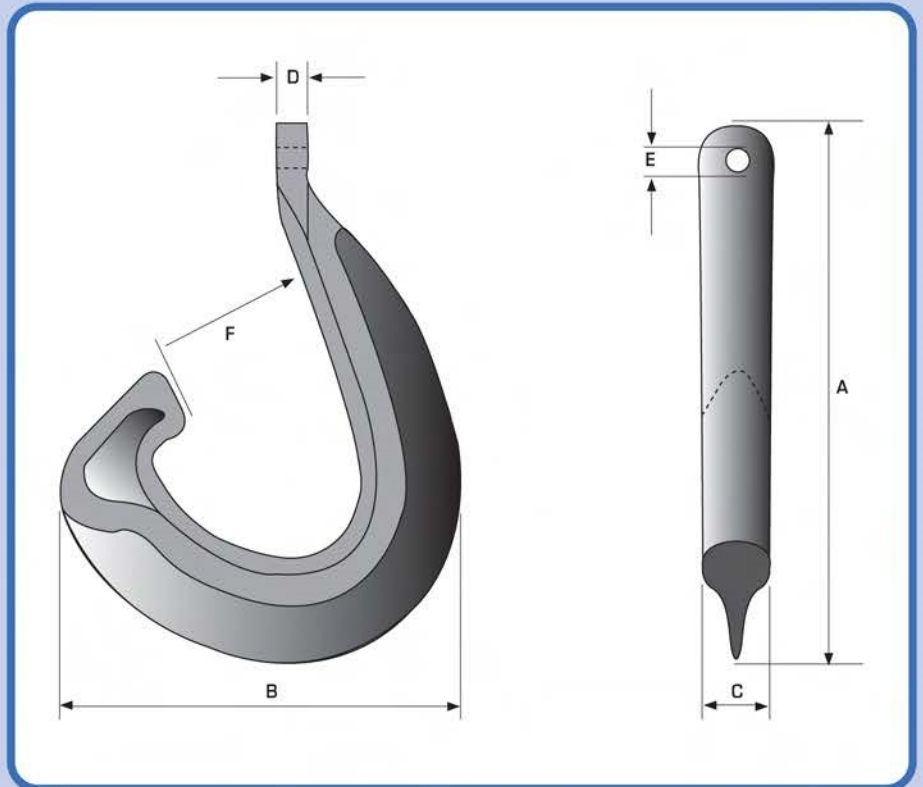

## TYPES: BEL 101 - BEL 4101

TYPE	S.W.L	PROOF TEST	WEIGHT		A	B	C	D	E	F
<b>BEL 101</b>	100 Tonnes	250 Tonnes	1886 kg	mm	2438	1829	305	124	86	699
<b>BEL 4101</b>	250 Tonnes	400 Tonnes	3400 kg	mm	2573	2185	457	178	144	699

All dimensions in millimetres

Lifting eye dimensions and Safe Working Loads are standard for each type. Specials can be made to suit customer requirements

**InterMoor Ltd**  
 Tern Place House  
 Tern Place, Bridge of Don,  
 Aberdeen AB23 8JX

Tel: +44 (0) 1224 701830  
 Fax: +44 (0) 1224 701831  
 Sales.uk@intermoor.com

