

BEL GRAPNEL PERMANENT WIRE CHASERS

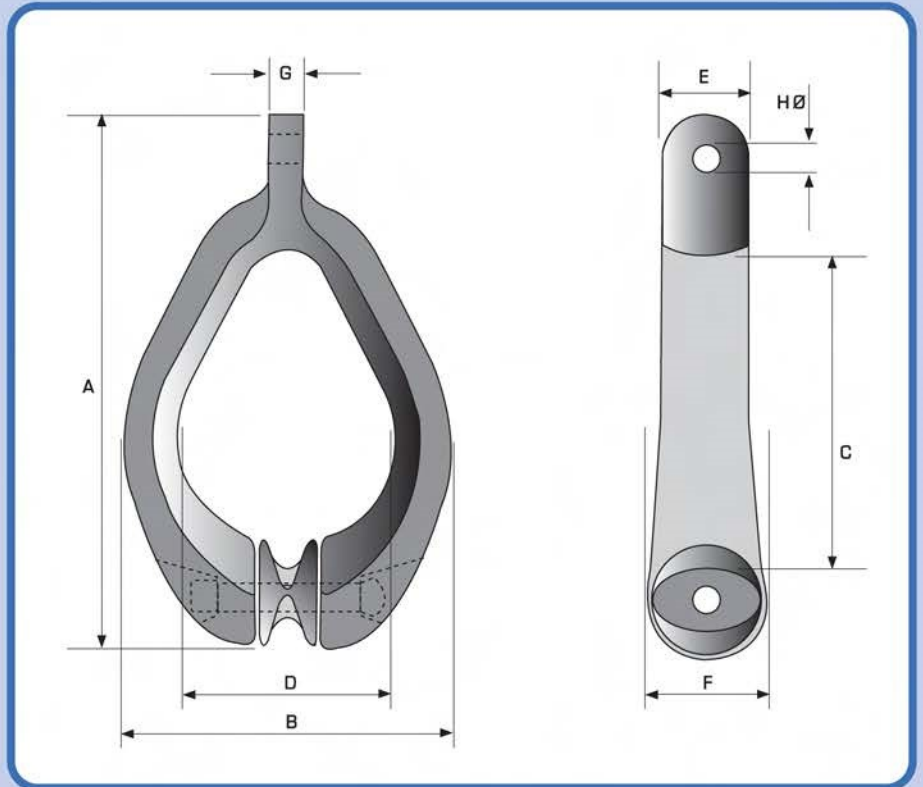

TYPES: BEL 210 - BEL 213 - BEL 214 - BEL 215 - BEL 4214

TYPE	S.W.L	PROOF TEST	WEIGHT		A	B	C	D	E	F	G	H
BEL 210	130 Tonnes	250 Tonnes	1984 kg	mm	2073	1245	1203	838	330	432	130	99
BEL 213	130 Tonnes	250 Tonnes	1866 kg	mm	1962	1099	1086	692	330	445	130	99
BEL 214	130 Tonnes	250 Tonnes	2526 kg	mm	2318	1308	1397	902	330	508	130	99
BEL 215	250 Tonnes	400 Tonnes	2495 kg	mm	2051	1168	1060	711	356	445	178	127
BEL 4214	250 Tonnes	400 Tonnes	4070 kg	mm	2548	1422	1397	902	394	610	178	144

All dimensions in millimetres

Lifting eye dimensions and Safe Working Loads are standard for each type. Specials can be made to suit customer requirements

InterMoor Ltd
 Tern Place House
 Tern Place, Bridge of Don,
 Aberdeen AB23 8JX

Tel: +44 (0) 1224 701830
 Fax: +44 (0) 1224 701831
 Sales.uk@intermoor.com

