

# BEL GRAPNEL

DETACHABLE CHAIN CHASERS

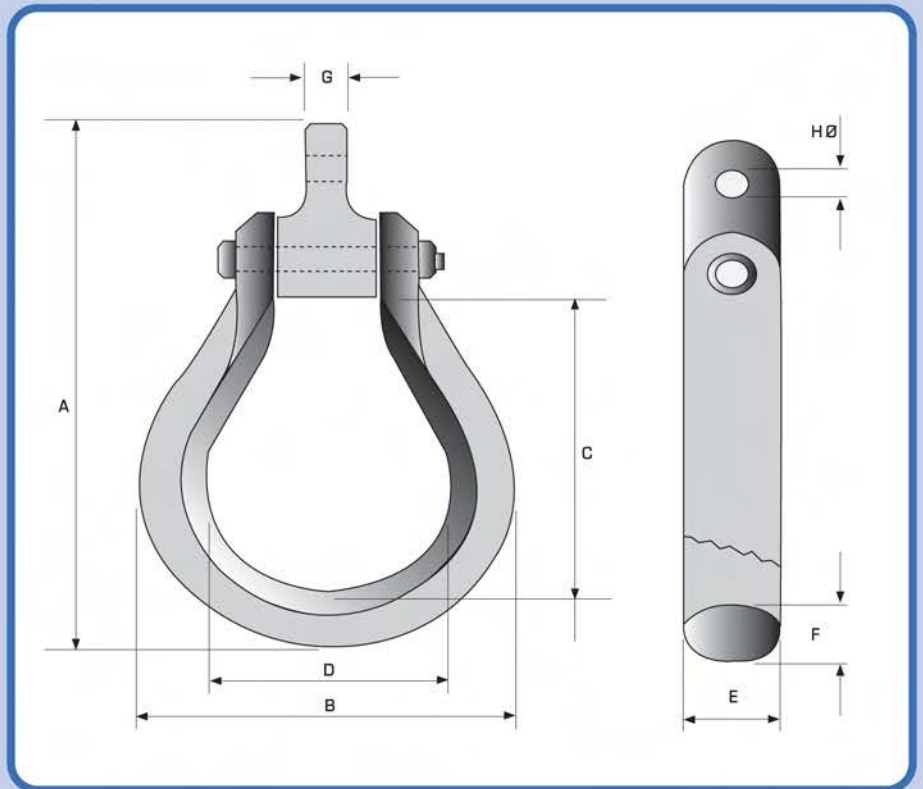

## TYPES: BEL 107 - BEL 108

TYPE	S.W.L	PROOF TEST	WEIGHT		A	B	C	D	E	F	G	H
<b>BEL 107</b>	100 Tonnes	250 Tonnes	1245 kg	mm	1886	1143	1080	762	305	191	124	86
<b>BEL 108</b>	130 Tonnes	250 Tonnes	1656 kg	mm	1931	1168	1067	762	381	203	130	99

All dimensions in millimetres

Lifting eye dimensions and Safe Working Loads are standard for each type. Specials can be made to suit customer requirements

**InterMoor Ltd**  
Tern Place House  
Tern Place, Bridge of Don,  
Aberdeen AB23 8JX

Tel: +44 (0) 1224 701830  
Fax: +44 (0) 1224 701831  
Sales.uk@intermoor.com

